

Model Year and Vehicle Rating

CAS RPM Seminar

Commitment Beyond Numbers



LeRoy Boison, FCAS, MAAA

Dallas, TX

March 10, 2015

Antitrust Notice

- The Casualty Actuarial Society is committed to adhering strictly to the letter and spirit of the antitrust laws. Seminars conducted under the auspices of the CAS are designed solely to provide a forum for the expression of various points of view on topics described in the programs or agendas for such meetings.
- Under no circumstances shall CAS seminars be used as a means for competing companies or firms to reach any understanding – expressed or implied – that restricts competition or in any way impairs the ability of members to exercise independent business judgment regarding matters affecting competition.
- It is the responsibility of all seminar participants to be aware of antitrust regulations, to prevent any written or verbal discussions that appear to violate these laws, and to adhere in every respect to the CAS antitrust compliance policy.

Distant Yesterday

- Based exclusively upon MSRP.
- Applied only to 1st party property coverages.
- Same Symbol for both comprehensive and collision.
- Combined with “Age” as opposed to “Model Year” Rating.

Yesterday

- Late 70's 2 significant changes
 - Introduction of Model Year Rating
 - Introduction of Damageability/Reparability into Symbol

Model Year Rating

Age	Factor	Model Year	Factor
		$X + 2$	$(1.05)(1.05)$
		$X + 1$	1.05
1	1.00	X	1.00
2,3	0.85	$X - 1$	0.95
4,5	0.75	$X - 2$	0.90
6 & over	0.65	$X - 3$	0.85

Model Year Rating

- Typically uses constant multiplicative relationship between model years
- Typically 5% for Comprehensive and Collision
- Limited to X model years with catch all for older vehicles

Model Year Rating

- Created a mechanism by which individual vehicle model years could be recognized – ***not really utilized except by several innovators.***
- Some companies are using for liability coverages – inconsistent - some positive, some negative – overlaps with mileage

Model Year

- The ability to use model year effectively together with specific models has not been realized.
 - E.G. If the 1995 Honda Civic or 2007 Toyota Corolla has the highest theft rate as recently published – shouldn't it have a higher rate than the later models?

Stolen Cars Vary By Model Year

- Here are the 10 most stolen vehicles as reported by the NICB — the number in parentheses is the model year most stolen:
- [Honda Civic](#) (1995)
- [Honda Accord](#) (1991)
- [Toyota Camry](#) (1989)
- [Ford F-150](#) (1997)
- [Chevrolet C/K 1500](#) (1994)
- [Acura Integra](#) (1994)
- [Dodge Ram Pickup](#) (2004)
- [Nissan Sentra](#) (1994)
- [Toyota Pickup](#) (1988)
- [Toyota Corolla](#) (2007)

Why older cars?

- For over 25 years, the National Insurance Crime Bureau (NICB) has published *Hot Wheels*, an annual report of America's 10 most stolen vehicles. While popular expectations have been that newer, more expensive vehicles would top the list, the data has repeatedly shown quite the opposite, with older, less flashy models topping the list
- Mid-1990 Hondas and Toyotas frequently dominate the yearly top-10 stolen car list. Because they are so popular, there is always a market for parts. Thieves like to steal them and chop them up, which can bring in more money than selling the car whole.

Progressive Rating

	Class	MM	Symbol	
1995 Honda Civic	HC1	0.99	5	
1989 Toyota Camry	TC1	0.96	8	
1991 Honda Accord	HA1	1.23	11	92-93 factor, 1.33 for '94-98, drops to .75 in 98
1994 Dodge Caravan	DG1	0.99	8	
1990 Acura Integra	AI1	0.99	14	
1991 Nissan Sentra	NS1	0.9	5	

Immobilizer

- 1999 and 2000 Honda Civics do not come with an electronic immobilizer, however all Hondas from 2001 and onward are equipped with an immobilizer. Immobilizers became mandatory on all new cars sold beginning September 2007. The devices enable an engine computer to recognize an electronic code in the key. If the code in the key and the engine don't match exactly, the vehicle can't be started.

Vehicle Rating

- New vehicles are usually rated by “comparison to similar” existing vehicle – **becoming less accurate as new, different vehicle type are being introduced.**

Significant Differences By Company for New Models

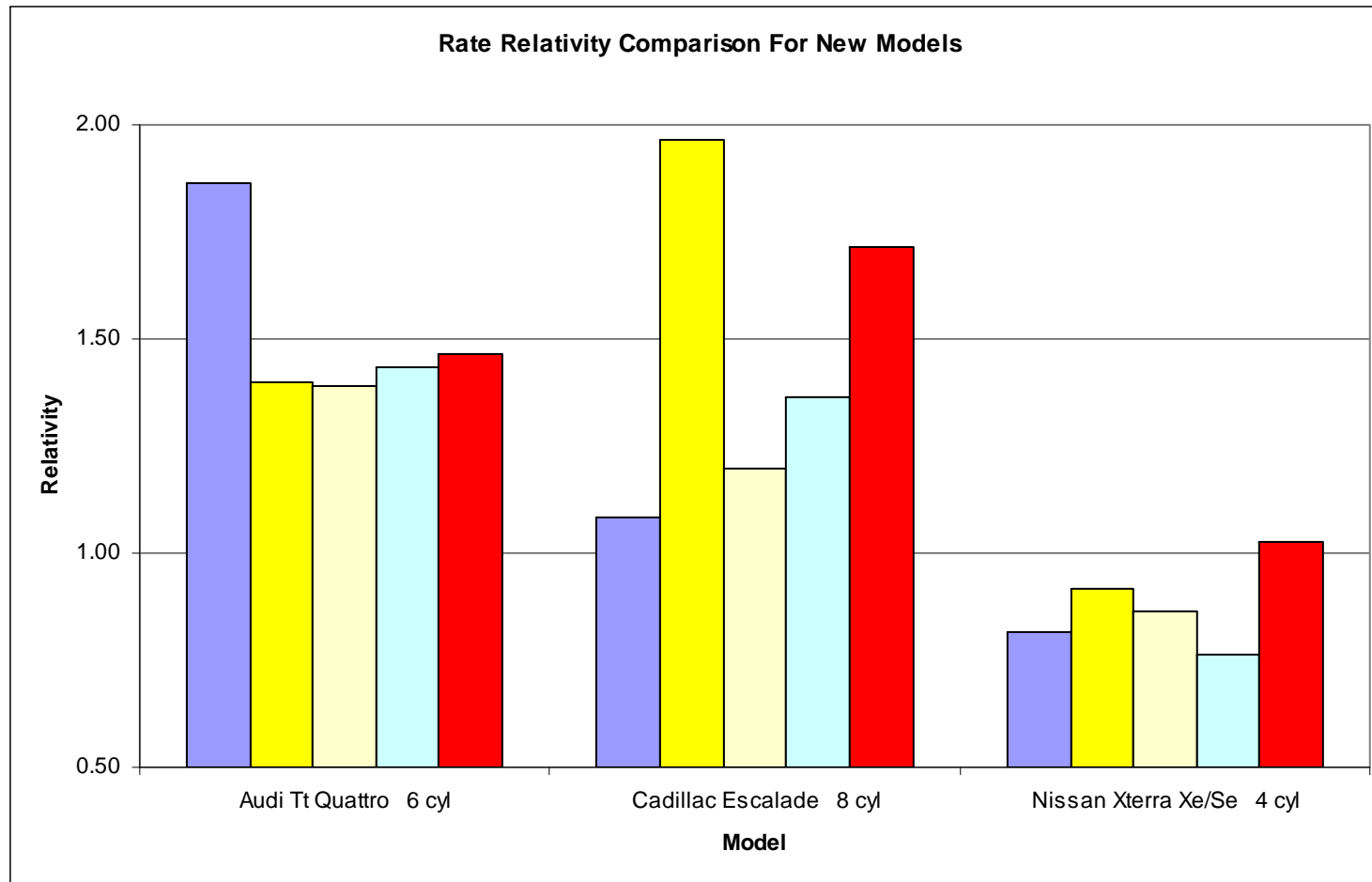

Significant Differences By Company for New Models

- Difference in rates $> 80\%$
- The Porsche Boxster symbol assignment from inception dropped at least 5 symbols.

Significant Differences By Company for Most Popular Models

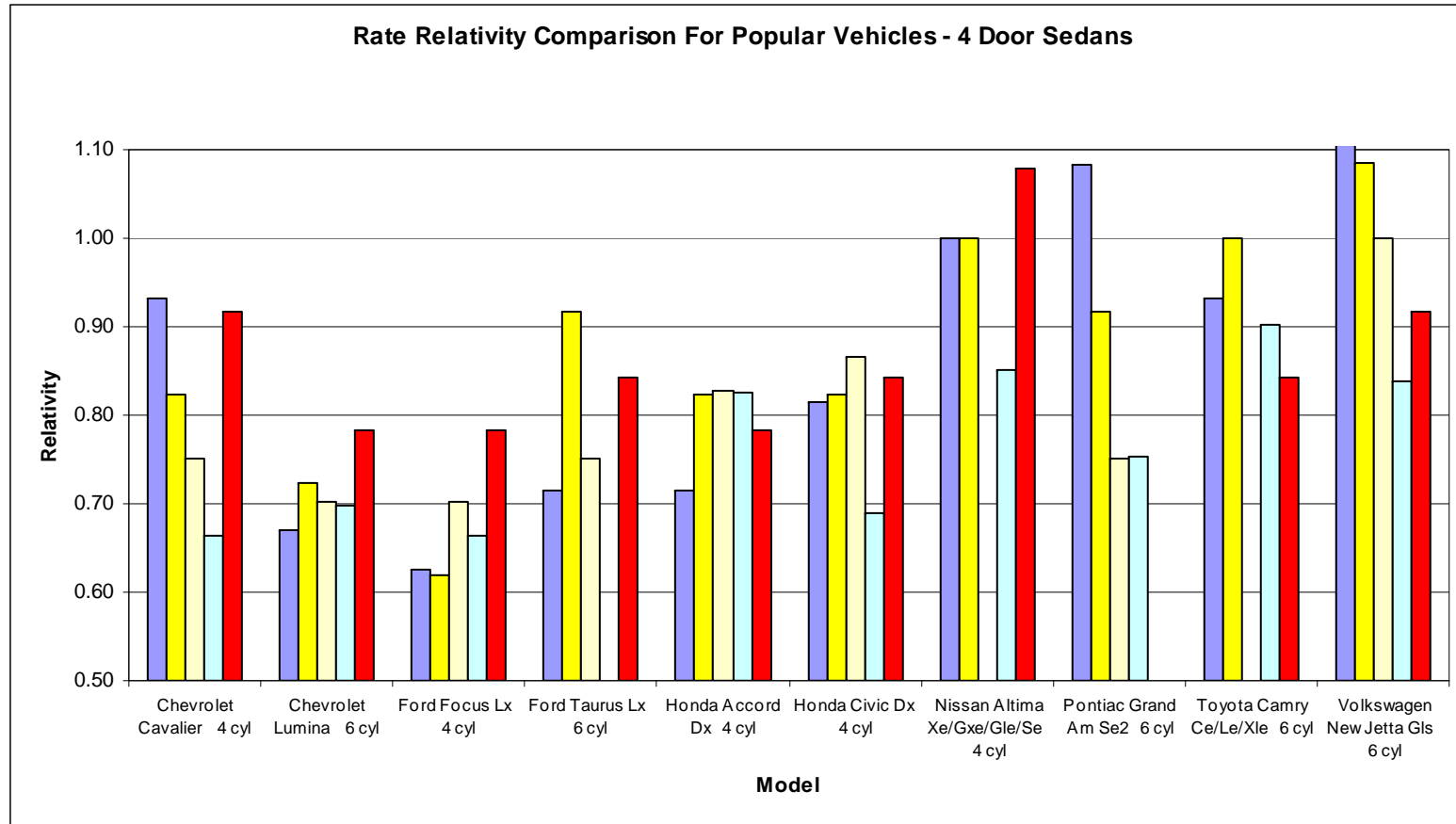

Significant Differences By Company for Most Popular Models

- Smallest difference with high and low company is 16%
- Greatest difference is 44%
- Average difference is 28%

Sports/Luxury Models

- Variations for “published” rates are 32% to 137%
- Differences may be greater as some companies do not provide “published” rates for these models

Differences Exist By Type of Models

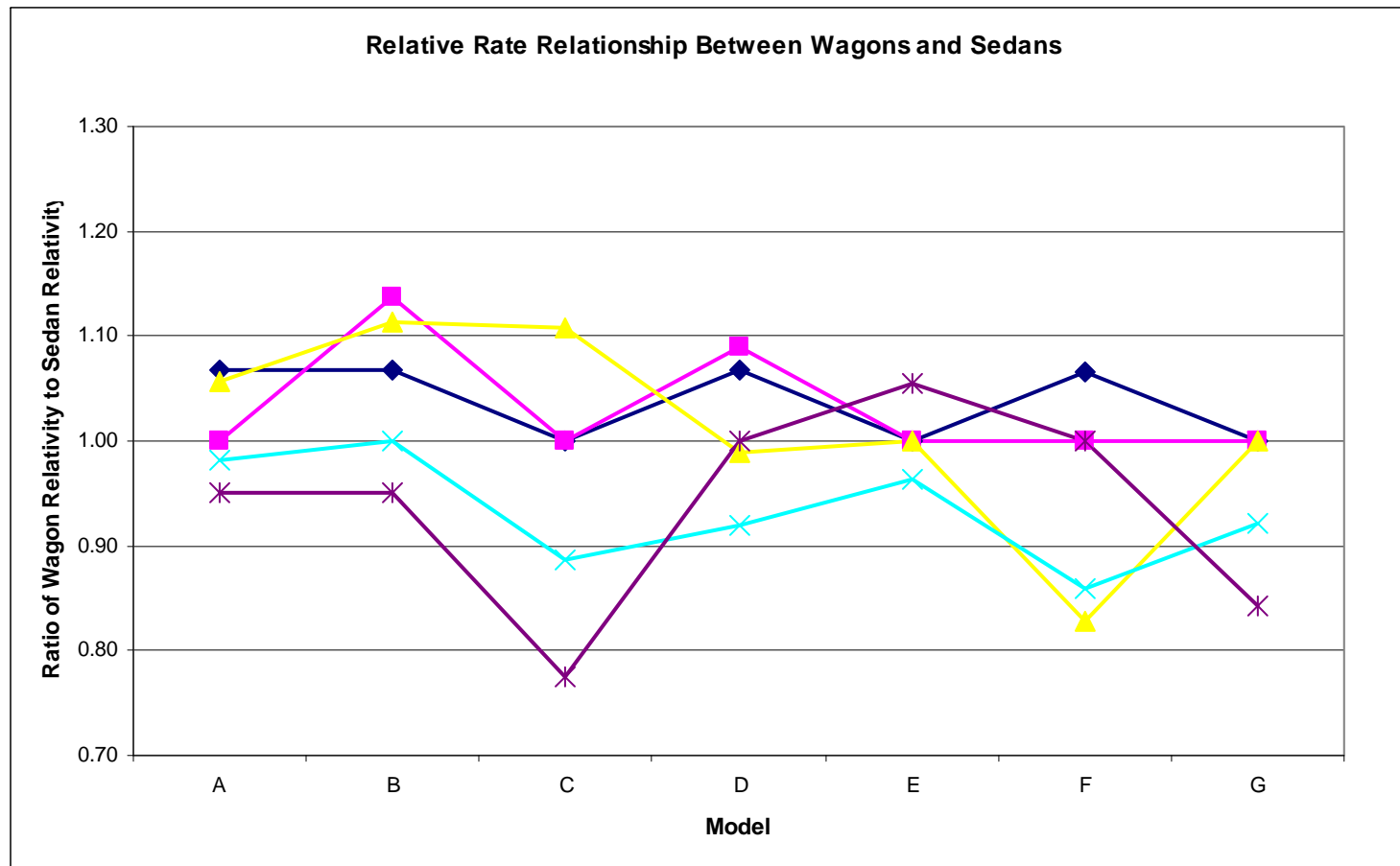

Differences Exist By Type of Models

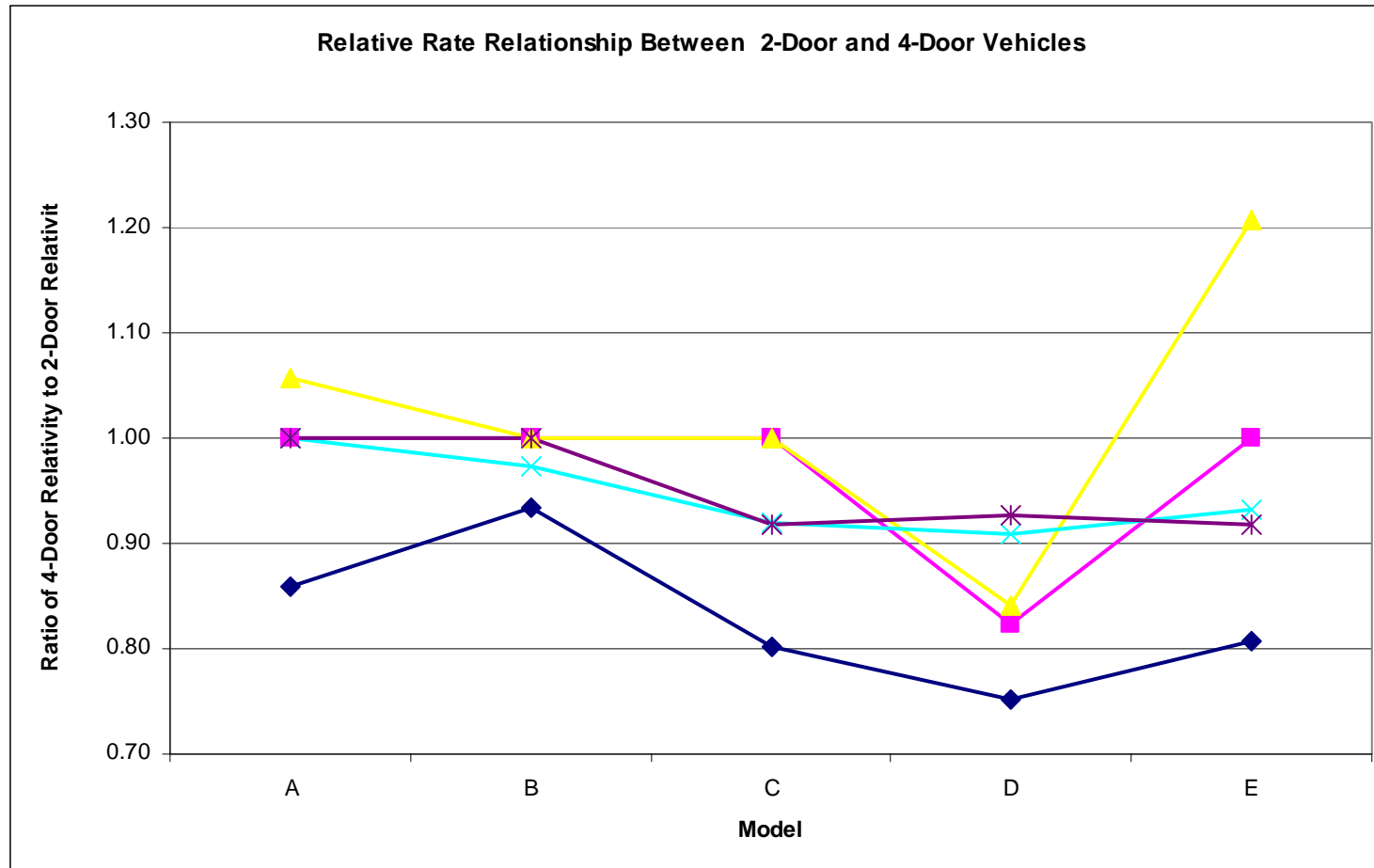

Percent of Collision Claims by Point of Impact By Vehicle Type

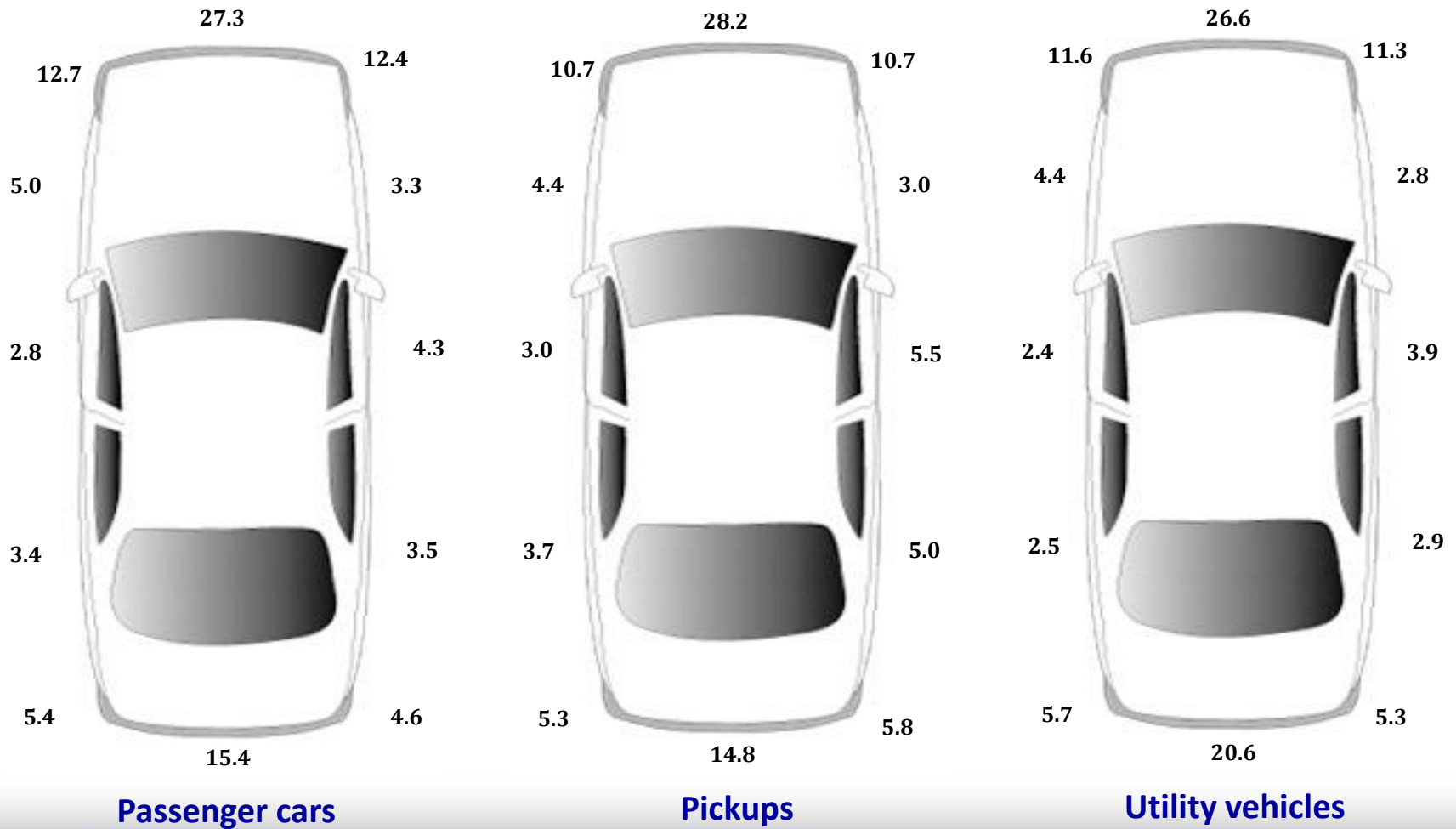

Percent of Property Damage Liability Claims by Point of Impact by Vehicle Type

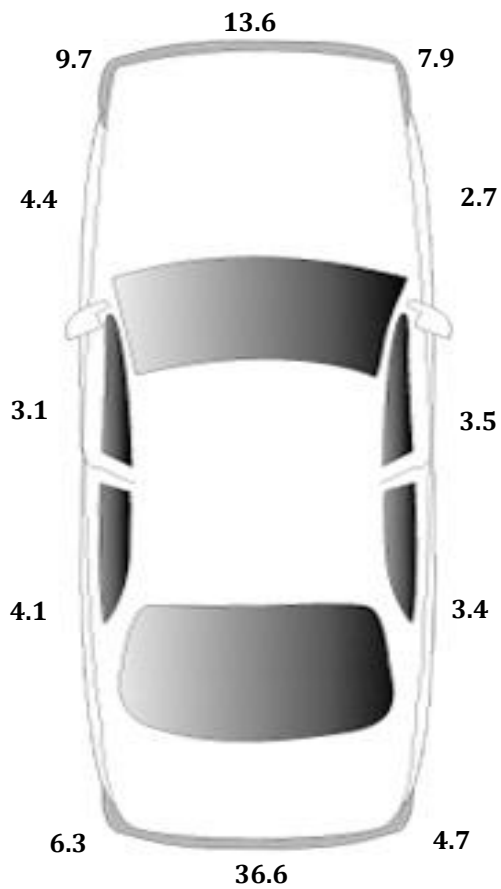

Passenger cars

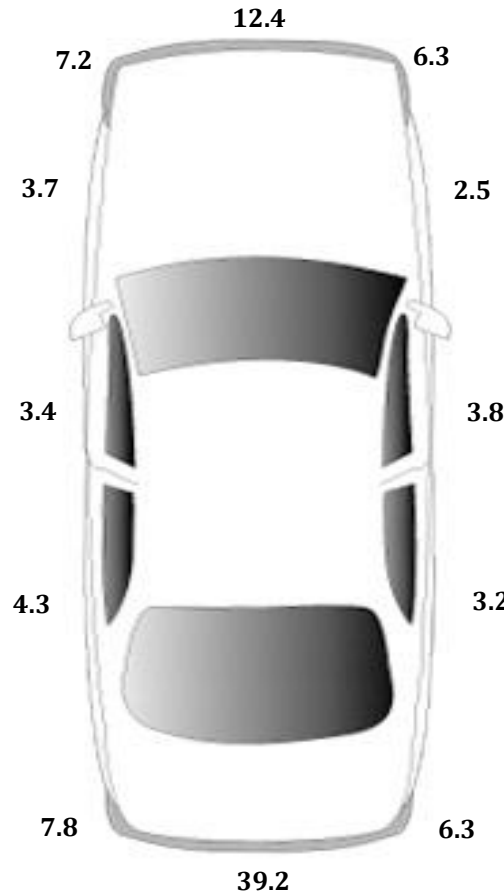

Pickups

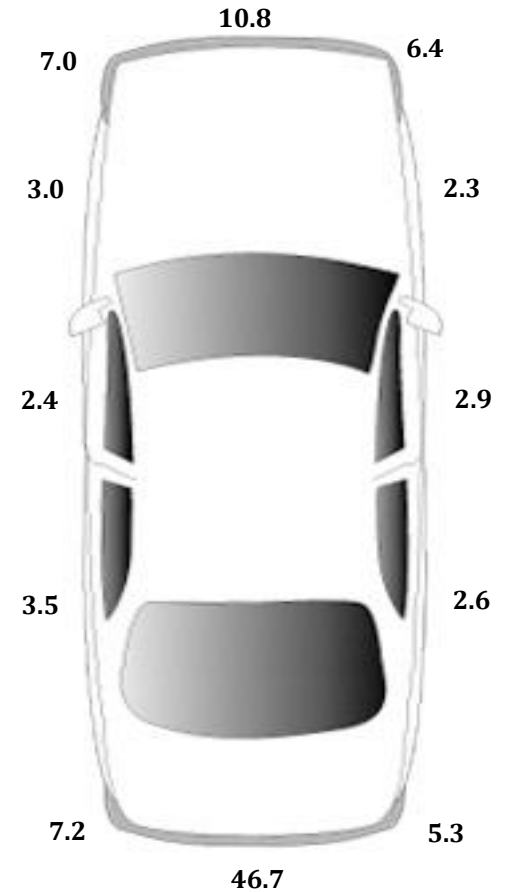

Utility vehicles

Solution to Rear Accidents

- Back up avoidance device
 - Infra red sensor
 - camera
- Mirror

Mandatory Backup Camera Legislation

- NHTSA estimates that once the new regulations will cost the auto industry between \$1.9 and \$2.7 billion annually, once they go into effect. The cost per vehicle would be just shy of \$159-\$203 for cars without a pre-existing navigation screen, and \$53-\$88 for cars with a screen.

Interestingly, NHTSA estimates the industry-wide expense of the measure at between \$1.9 billion to \$2.7 billion, and it reportedly acknowledges that its own cost-benefit analysis standards indicate that the price tag of the regulation will far outstrip the cost associated with lives saved by the law. That is, NHTSA uses a working figure of the "comprehensive cost for a statistical life" at \$6.1 million, but the costs per life saved by the backup camera legislation would likely tally somewhere between \$11.3 to \$72.2 million.

Electronic Stability Control

- Electronic stability control could prevent nearly one-third of all fatal crashes and reduce rollover risk by as much as 80%;
effect is found on single- and multiple-vehicle crashes

ESC - availability

- In 2006 ESC was standard on 40 percent of passenger vehicle models and optional on another 15 percent. It's standard on every 2006 Audi, BMW, Infiniti, Mercedes, and Porsche. Another 8 vehicle makes (Cadillac, Jaguar, Land Rover, Lexus, Mini, Toyota, Volkswagen, and Volvo) offer at least optional ESC on all of their models. But ESC, standard or optional, is limited to 25 percent or fewer models from Chevrolet, Dodge, Ford, Hummer, Mazda, Mitsubishi, Saturn, Subaru, and Suzuki
- **Mandatory on all 2012 vehicles**

Aluminum Parts, Hybrid Cars Boost Crash Costs

- Auto repair costs are going up in part because of changes in parts and new, more complex vehicles, an insurance information management firm said.

-(NU Online News Service, March 3, 12:25 p.m. EST)

**03-07 Infiniti G35 Coupe LED Strip Angel Eye
Halo Projector ...**
\$374.99 from ProTuningLab



**Or Replacement 12-1539-01 Turn Signal Light -
Clear lens, Plastic lens,) \$24.35**



What do Callaway Golf Clubs and Lamborghini have in common?



Confidential and Proprietary

Woven Carbon Fiber vs. Forged Carbon



Driving Technology

The photo above shows part of a Callaway club using traditional weave (left) versus one using Forged Composite. In the latter case, fiber chips are mashed together like composite hash browns and formed in a mold so accurate that even part numbers can be stamped into the piece.



Forged Carbon advantages



- Standard woven carbon fiber is typically made layer by layer and infused with epoxy or in premade sheets, which are baked to a form in a vacuum oven known as an autoclave.
- Forged composite takes a different route by taking a toothpaste-like mixture of carbon fibers and epoxy and forming parts in a mold with over six tons of pressure.
- The result is cheaper carbon-fiber-reinforced materials that can be made in less time.

Confidential and Proprietary. ©2010 Mitchell International, Inc.

New Electric Cars – Tesla Model X



Tesla

- Range of 300 miles
- Model X Performance accelerates from 0 to 60 mph in less than 5 seconds
- Model S Performance accelerates from 0 to 60 in 4.4 seconds, faster than a Porsche 911 Carrera.

Edmunds - Top 10 High-Tech Car Safety Technologies

1. Tire-pressure monitoring
2. Adaptive cruise control/collision mitigation
3. Blind-spot detection/side assist/collision warning
4. Lane-departure warning/wake-you-up safety
5. Rollover prevention/mitigation
6. Occupant-sensitive/dual-stage airbags
7. Emergency brake assist/collision mitigation
8. Adaptive headlights and/or night-vision assist
9. Rearview camera
10. Emergency response

Lane departure warning

- **Lane departure warning** helps keep inattentive drivers from inadvertently veering into another lane of traffic and causing a collision, which the National Traffic Safety Administration says accounts for 17 percent of all vehicle crashes. The system looks for highway lane markings via an embedded camera and generates a signal if the vehicle is in the process of crossing them; engaging the turn signals before purposefully changing lanes temporarily deactivates the alert. A few systems can “nudge” the car back into their lane if necessary via braking or steering intervention.

Collision warning/avoidance

- **Collision warning/avoidance** works with an advanced version of cruise control that uses sonar sensors to maintain both a set speed and distance from the nearest car in its path. If the sensors determine the car is closing in on the vehicle or other obstruction in its path too quickly (like when the driver isn't paying close enough attention) it will engage audible and visual alerts, tension the safety belts and pre-prime the brakes to full force in anticipation of an emergency stop. Lexus' system goes a step further by using a small camera to monitor the driver's eyes and will activate itself sooner if he or she is not looking forward at the time. Some systems will take over and apply the brakes if the driver isn't reacting quickly enough to help avoid or minimize the impending collision.

Blind-spot warning

- **Blind-spot warning** employs a set of sensors and/or cameras to detect other cars just to the side and rear of a vehicle and alerts a driver to their otherwise unseen presence. Some blind spot warning systems further include a Cross Path Detection function that also warns motorists of traffic that's approaching from the side when backing out of a parking space or garage. Infiniti's latest twist on the technology, called Blind Spot Avoidance, will actually intervene with selective braking to help a motorist avoid sideswiping another vehicle

Not all new technology have worked as expected

- Anti-lock brakes
- 3rd brake lock

Conversely – “Good” or “Bad” New Technology

- Blue tooth – “hands free” phone
- Windows enabled
- Email transcription – digital/oral

Lexus - Enform[®]



Smart Phones

- The demand for Internet technology is rising to new heights with the news today that by 2016, 92 million vehicles will feature technology to integrate smartphones into motor vehicles, according to a new report by [Juniper Research](#), forecasting smartphone-automobile integration as “all but standard” within five years.
- Although insurers will see certain inherent risks, such as the potential for an increase in distracted driving incidents, the benefits will be in the technology's ability to deliver commercial Telematics.

Effect of Recent Economic Crisis on Rating

- New cars sales for January '09 down 40-50%
- Cash for clunkers
- Premium trend effects
- Potential effect on older cars which are being kept longer
- More fuel efficient cars

The new small cars

Fiat-Chrysler 500



Chevrolet Sonic



Ford Fiesta

Confidential and Proprietary. ©2010 Mitchell International, Inc.

Trends Towards Lighter Vehicle Persists

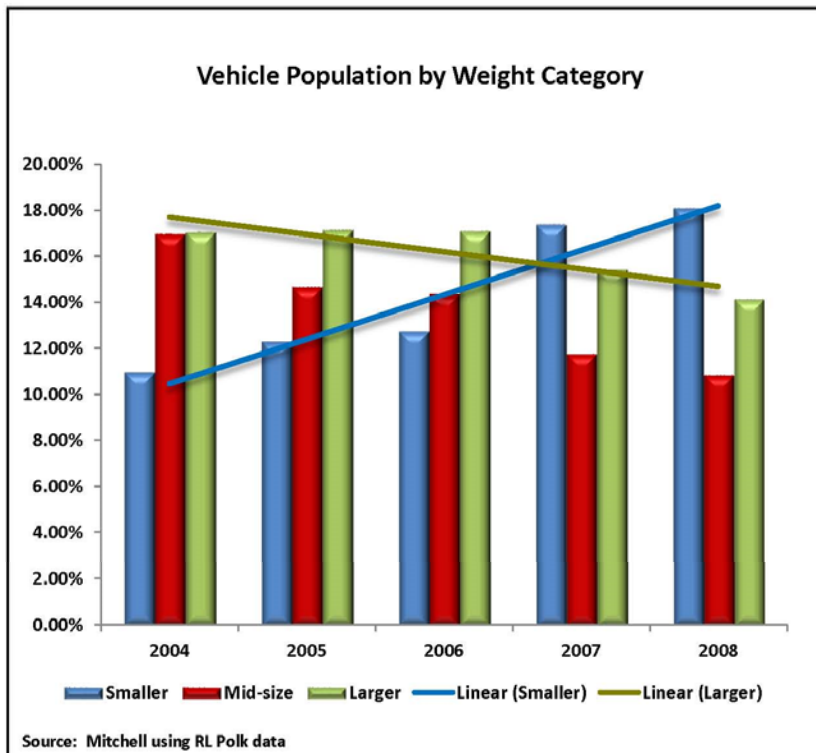

February 21, 2011 Page 16

Confidential and Proprietary. ©2010 Mitchell International, Inc.

Vehicle Size Mix

- From 2006 to 2007, smaller cars passed larger vehicles in numbers on the road
- Mid-size and heavier vehicle steadily decrease since 2006
- SUV's are only 7.9% of 2010 new vehicle sales
- Small cars are getting more options

Telematics

- And of course – how is the car itself driven
- Supplemental to rating based on Damageability/Reparability
- Extremely important but is more a driver rating rather than vehicle rating issue

Average Age of Cars > 10 years

CCC: How Vehicle Age, New Sales Affect Claims Severity, Frequency

- **Older Fleet Dominate Roads, But
Are Car Sales Finally Rising?**

Vehicle Age Share of Market

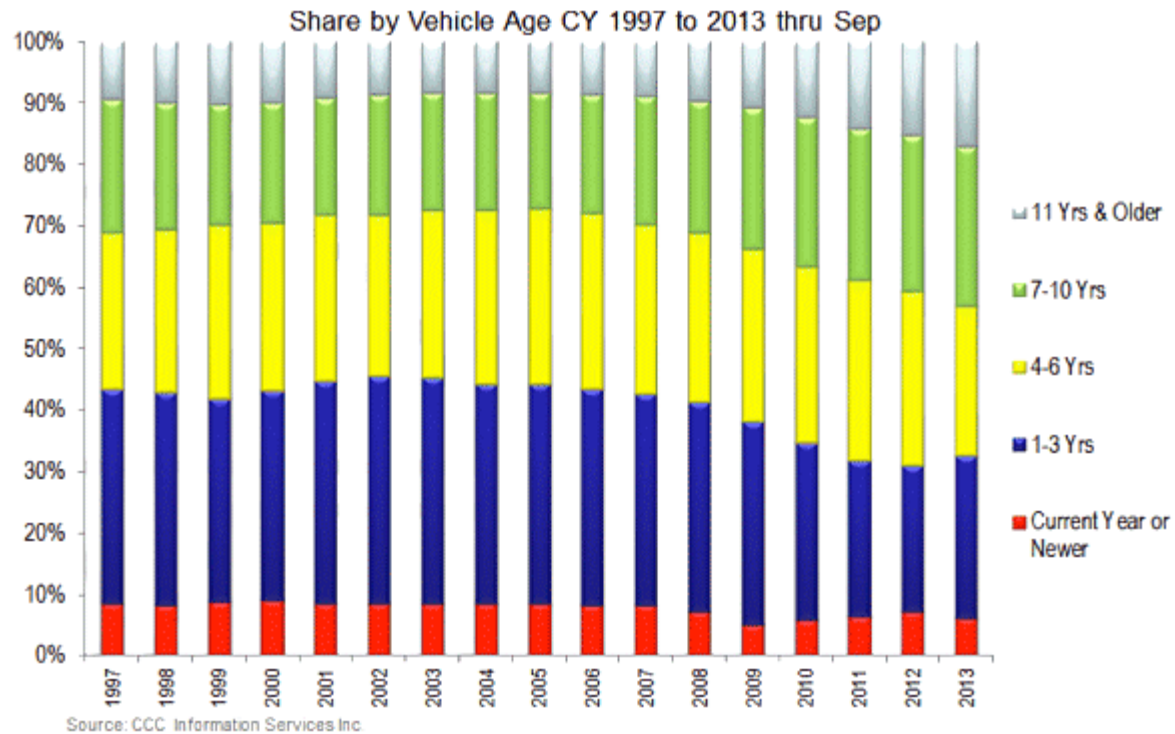

Percent of Repairable Appraisals

- Nearly 42% were for vehicles > 7 years old in 2013
- This was the highest ever recorded in last 15 years
- Over last 4 years, newer vehicles increased share but constitute small percentage of repairs

Repairable Appraisal Count Share

Share of Overall Repairable Appraisal Count
Comparison of Vehicles MY 2003-2007 versus MY 2008-2012 by Year on
Road and within Auto Claims

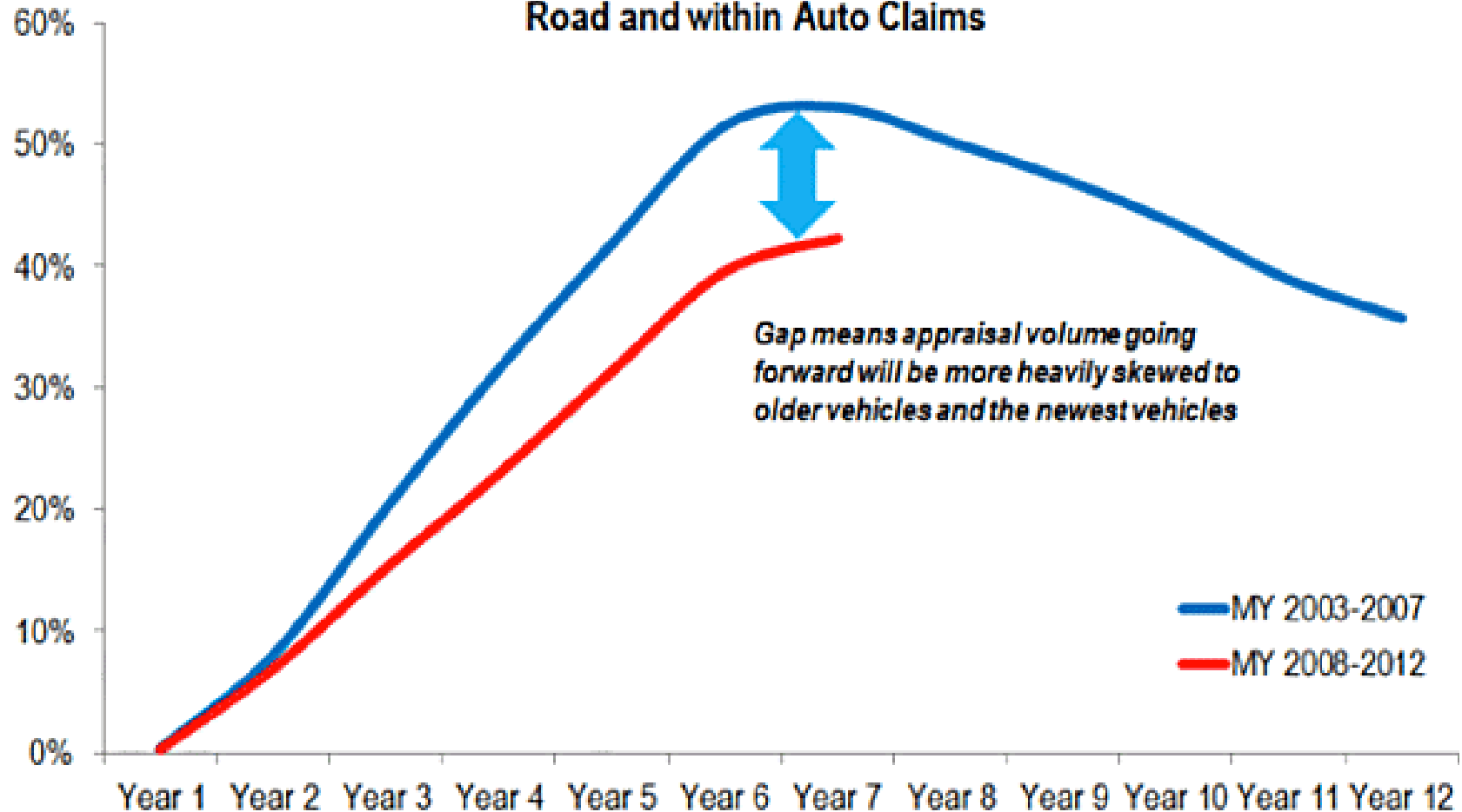

Source: CCC Information Services Inc.

New Technology Implementation

- Per 2011 HLDI – typically takes 3 decades before 95% of fleet has feature as standard or option.
- Quicker obviously if mandated.

Collision Avoidance System Impact

Potential Impact on Frequency for All Losses as Collision Avoidance Systems are Adopted

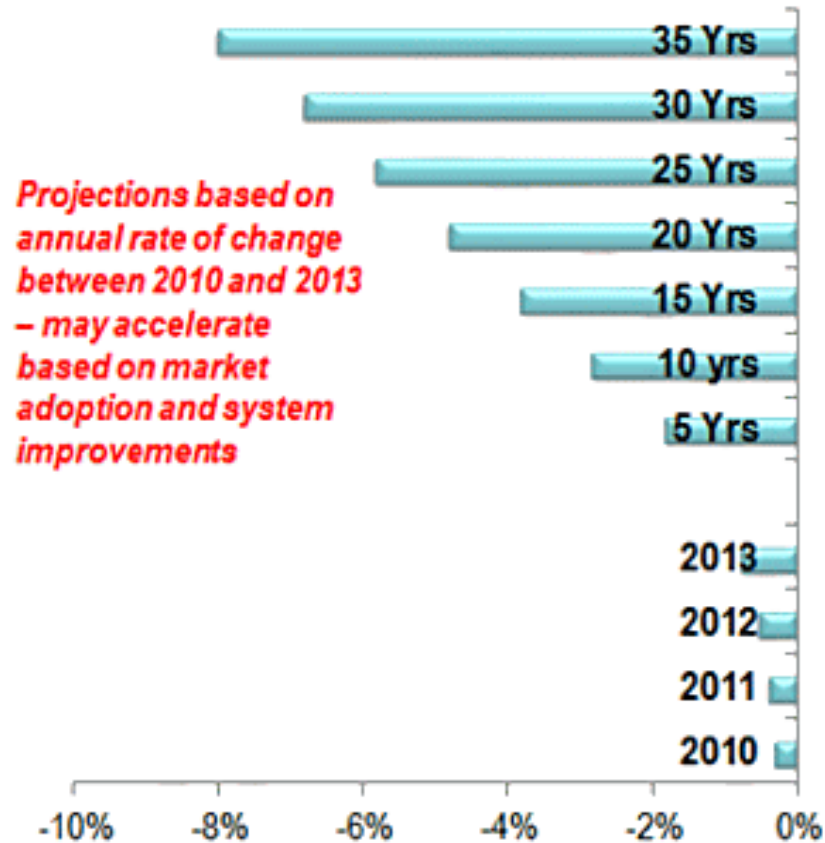

Source: CCC Information Services Inc.

On the Horizon

Autonomous Driving

Google's modified Toyota Prius uses an array of sensors to navigate public roads without a human driver. Other components, not shown, include a GPS receiver and an inertial motion sensor.

LIDAR

A rotating sensor on the roof scans more than 200 feet in all directions to generate a precise three-dimensional map of the car's surroundings.

POSITION ESTIMATOR

A sensor mounted on the left rear wheel measures small movements made by the car and helps to accurately locate its position on the map.

VIDEO CAMERA

A camera mounted near the rear-view mirror detects traffic lights and helps the car's onboard computers recognize moving obstacles like pedestrians and bicyclists.



RADAR

Four standard automotive radar sensors, three in front and one in the rear, help determine the positions of distant objects.

Source: Google

THE NEW YORK TIMES, PHOTOGRAPHS BY EMIN RAHMAN FOR THE NEW YORK TIMES

Car-to-car warning Systems

- **Talking-Car Systems to Be Required as U.S. Weighs Rules**

Future Forward: How to Regulate Connected Cars

- U.S. regulators will propose rules before President [Barack Obama](#) leaves office requiring vehicle-to-vehicle communications systems in new cars, a move advocates said may aid safety more than seat belts and air bags.
- “Vehicle-to-vehicle technology represents the next generation of auto safety improvements,” Transportation Secretary Anthony Foxx said at a news conference today. “The potential of this technology is enormous.”

Smart Bumpers

BMW smart bumper

BMW will also use lasers make the i3 unscratchable when the driver is in control. At speeds below 15km/h, sensors put a shield around the car and auto brake it when it detects the driver is about to scrape something. Ideal for avoiding car park dings: a genuine ‘smart bumper’ says BMW.

Audi Tablet

Audi revealed its very own self-designed tablet. The metal device is weighty and premium, and has a special screen that you can view even in direct sunlight. It'll launch in the new Q7 later this year.

BMW OLED tail lights

Organic LED tail lights are also coming to BMW. The thin, intense light source is highly flexible and gives designers a much broader canvas to work with. They're coming to market on an M car within 18 months.



Seeing Machines

Intel and eye-tracking tech firm Seeing Machines revealed a prototype Jaguar F-Type cockpit at CES 2015. This has a laser monitoring the driver, as well as outside: it can detect both when they're distracted and, crucially, knows exactly what they may be missing as they look away - and automatically help the car respond accordingly

Mercedes-Benz F 015

The 'living room on wheels' was a massive draw at CES 2015. Mercedes-Benz wants it to be a 'third place', offering what it thinks will be truly valued luxuries in the future - time and private space.



Next?



Thank You for Your Attention

LeRoy Boison, FCAS, MAAA

516.287.4330

lboison@pinnacleactuarial.com

