

TRUE  
M I L E A G E



Technology and Analytics for Usage-Based Auto Insurance (UBI)

# UBI Technology



CAS RPM Dallas 2015

Ryan N. Morrison, CEO

True Mileage, Inc. | [info@truemileage.com](mailto:info@truemileage.com) | 888.495.2334

# UBI Technology

## Agenda

- 1) Mileage Technology
- 2) Variables
- 3) Insurer Mileage+ Technology
- 4) Telematics Clearinghouse
- 5) Independent Mileage+ Technology
  - Hybrid Approach



# (1) Mileage Technology

## Mileage

- Self Reported
- Historic
- Odometer
- Mileage +



# (1) Mileage Technology

## Mileage

- Self Reported
- Historic
- Odometer
- Mileage +





# (1) Mileage Technology

## Mileage

- Self Reported
- **Historic**
- Odometer
- Mileage +



# (1) Mileage Technology

## Mileage

- Self Reported
- Historic
- Odometer
- Mileage +



# (1) Mileage Technology

Typical on-going verified mileage discounts today:

Mileage Up To	Discount
2,500	54%
5,000	39%
7,500	34%
<b>10,000</b>	<b>26%</b>
12,500	18%
15,000	13%
15,000 +	7%



# (1) Mileage Technology

Driver Age

## Rating Mileage Table

8,000  
Rating Mileage

16,000  
Rating Mileage

$$\text{Discount} = \text{Max Discount} \cdot \left(1 - \frac{\text{Mileage}}{\text{Rating Mileage}}\right)$$

Vehicle Age

Mileage Discount Analytics™



# (2) Variables

## Daytime Discount Analytics™

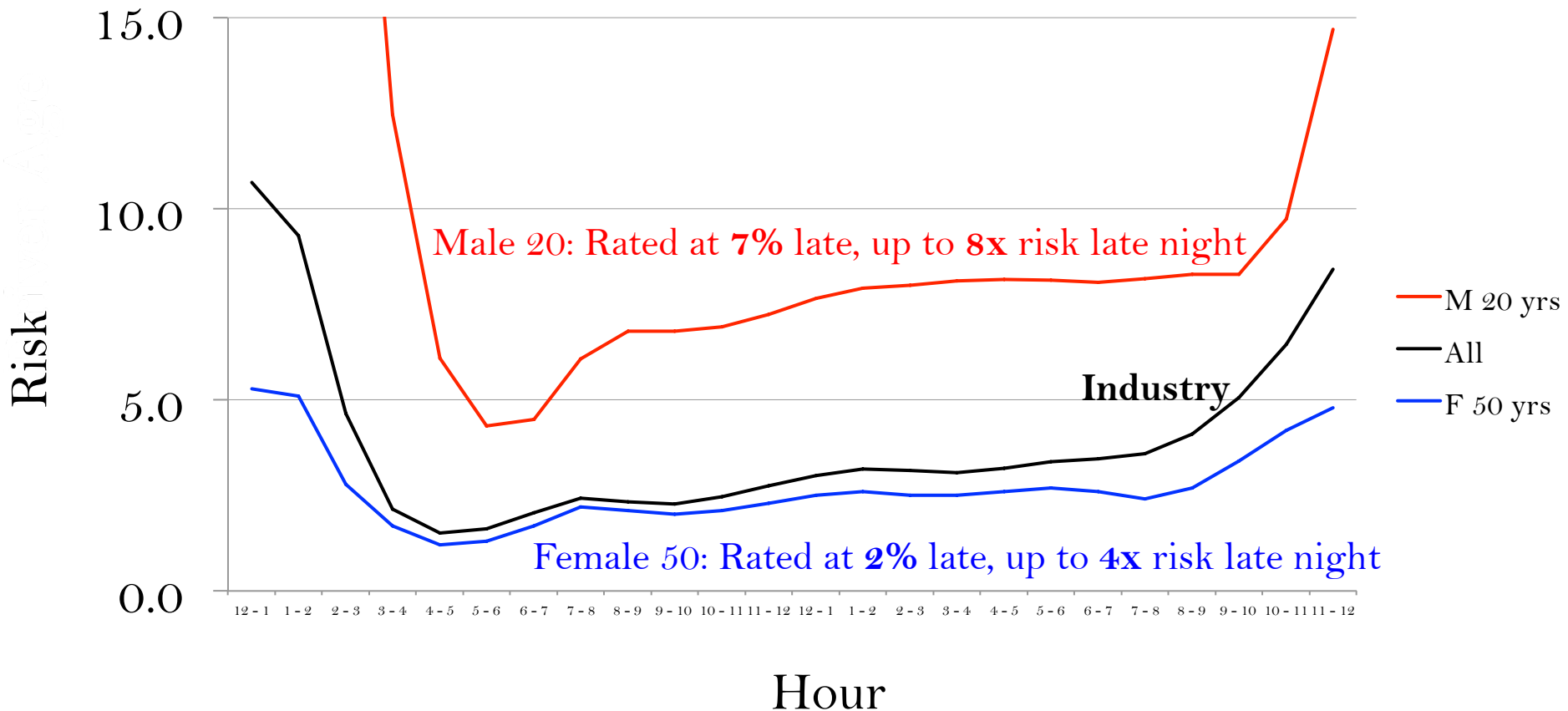

## (2) Variables

### UBI Variables

- **Mileage** (Mileage Discount Analytics™)
- **Time of Day** (Daytime Discount Analytics™)
- **Accelobrakes**
- **Hard Brakes**
- **Cornering**
- **Acceleration**
- **High Speed**
- **Location** (road, weather, traffic)



# (3) Insurer Mileage+ Technology

## Options

- OBD / Modem Devices – Savings Focus
- OBD / Modem Devices – Services Focus
- Stand-Alone Apps
- OBD / Mail Devices





# (3) Insurer Mileage+ Technology

## Options

- OBD / Modem Devices – Savings Focus
- OBD / Modem Devices – Services Focus
- Stand-Alone Apps
- OBD / Mail Devices



# (3) Insurer Mileage+ Technology

## Options

- OBD / Modem Devices – Savings Focus
- OBD / Modem Devices – Services Focus
- Stand-Alone Apps
- OBD / Mail Devices



# (3) Insurer Mileage+ Technology

## Options

- OBD / Modem Devices – Savings Focus
- OBD / Modem Devices – Services Focus
- Stand-Alone Apps
- OBD / Mail Devices

censio

rivewaySoftware



# (3) Insurer Mileage+ Technology

## Options

- OBD / Modem Devices – Savings Focus
- OBD / Modem Devices – Services Focus
- Stand-Alone Apps
- **OBD / Mail Devices**  
(True Mileage 1)

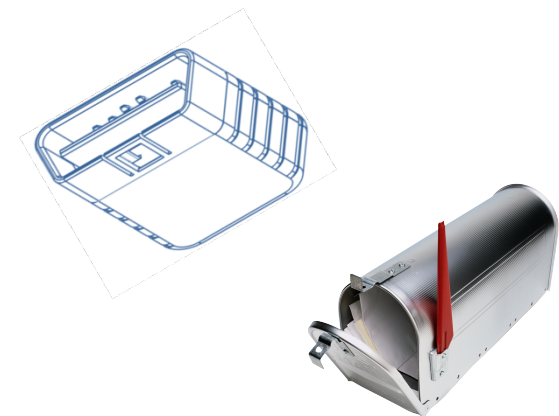

# (4) Telematics Clearinghouse

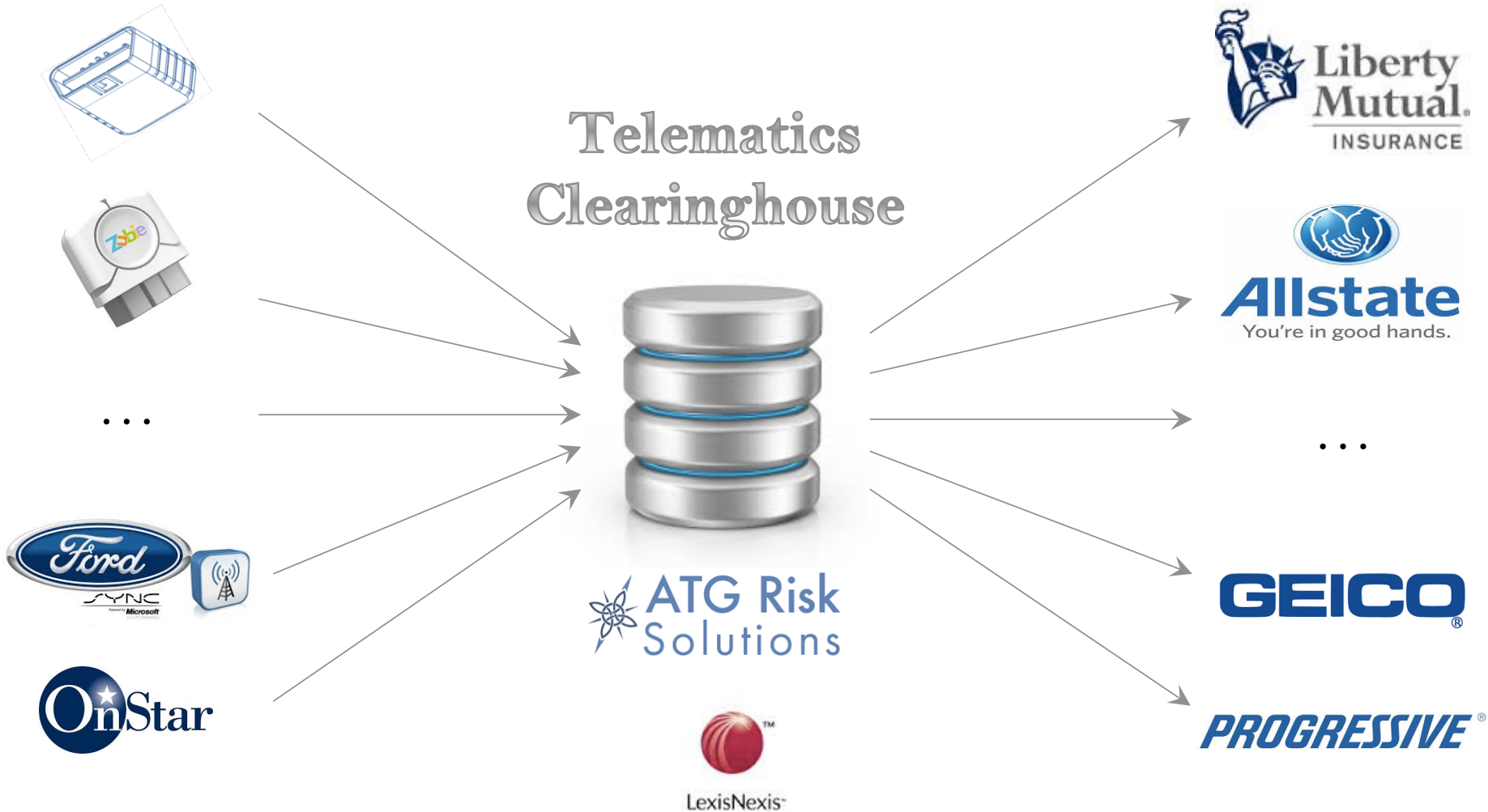

# (5) Independent Mileage+ Technology

## Options

- OBD / Modem Devices – Services Focus
- Manufactures
- OBD / Smartphone Hybrid Devices



# (5) Independent Mileage+ Technology

## Options

- OBD / Modem Devices – Services Focus
- **Manufactures**
- OBD / Smartphone Hybrid Devices





# (5) Independent Mileage+ Technology

## Options

- OBD / Modem Devices – Services Focus
- Manufactures
- OBD / Smartphone Hybrid Devices  
(True Mileage 2)

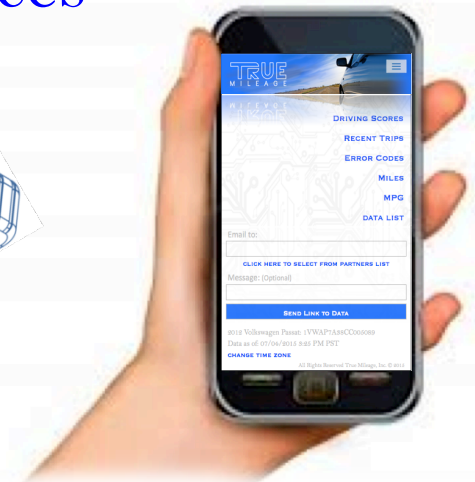
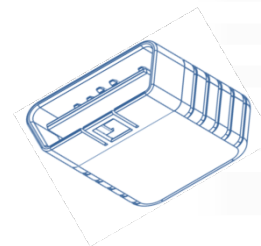



## Summary

### Insurance Savings

Mileage	5,361	★★★★☆
Brakes	119	★☆☆☆☆
Daytime	94%	★★★★☆

Past 275 days / 11 days disconnected > 5 min.  
7,115 annual mileage.

### Recent Trips

Date	Time	Miles	Cost
06/14/14	10:10 am	6	\$3.36
06/14/14	8:40 am	36	\$20.16
06/14/14	7:09 am	21	\$11.76

Cost at 2014 rate of \$0.56 per mile.

### Error Codes

[P0420](#) Catalyst System Efficiency Below Threshold

[P0560](#) System Voltage

[P0570](#) Cruise Control Accelerate Signal

[P2002](#) Particulate Trap Efficiency Below Threshold

[P2003](#) Particulate Trap Efficiency Below Threshold

[P0546](#) Exhaust Gas Temperature Sensor Circuit High

[www.truemileage1.com](http://www.truemileage1.com)  
click: [Example Dataset](#)

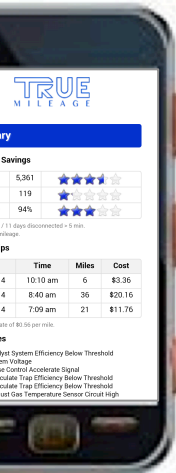

## P0420 - Catalyst System Efficiency Below Threshold Bank 1

### Possible causes

- Three way catalyst converter Bank 1
- Exhaust tube
- Intake air leaks
- Fuel injectors may be faulty
- Fuel injector leaks
- Spark plugs may be faulty
- Improper ignition timing
- Engine Control Module (ECM)

[What does this mean?](#)

### Tech notes

As the code description implies the P0420 code means that the vehicle's control module has detected that the three-way catalytic converter is not working properly (not as efficient as the factory is expecting). Replacing the oxygen (O2) sensors may sometimes fix the problem, but in most cases the catalytic converter needs to be replaced to fix the problem. If the P0420 code is combined with other codes, try fixing the other codes first.



# (5) Independent Mileage+ Technology

## OBD / Smartphone Hybrid Devices

Voted by experts as most likely approach to dominate UBI over next 5 years

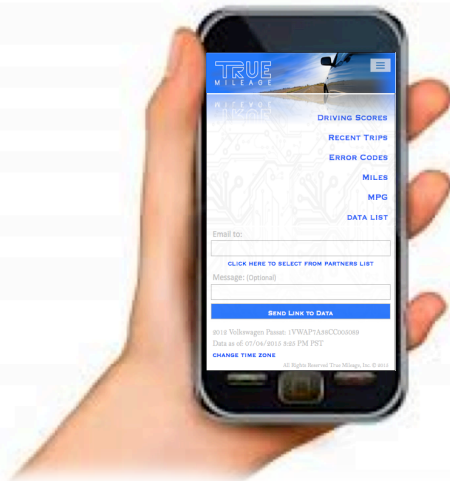
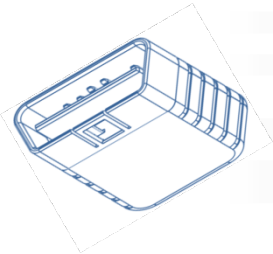

- 1) Device 40% less
- 2) Data 100% less
- 3) Data available
- 4) Privacy
- 5) Reliable



TRUE  
M I L E A G E

Technology and Analytics for Usage-Based Auto Insurance (UBI)

Thank You!

Visit True Mileage at Booth #8



CAS RPM Dallas 2015

Ryan N. Morrison, CEO

True Mileage, Inc. | [info@truemileage.com](mailto:info@truemileage.com) | 888.495.2334